

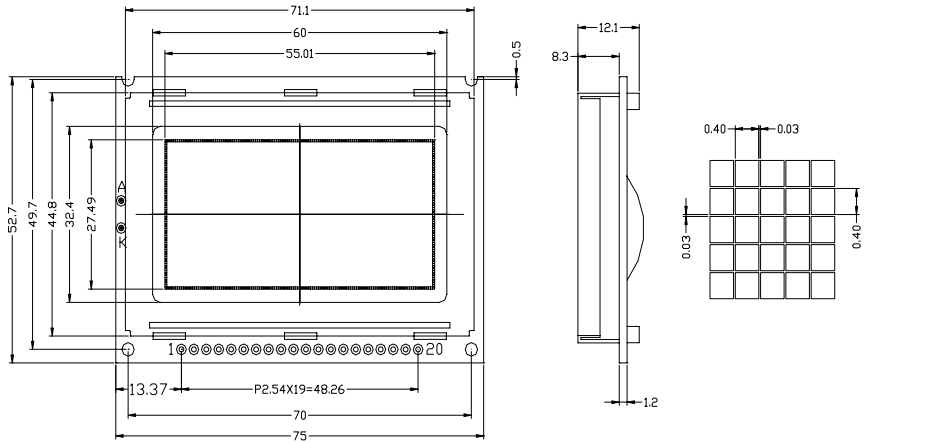

• EXTERNAL DIMENSIONS:

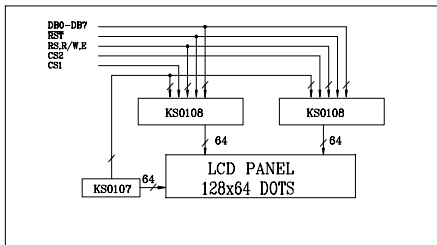

• BLOCK DIAGRAM:



• POWER SUPPLY:

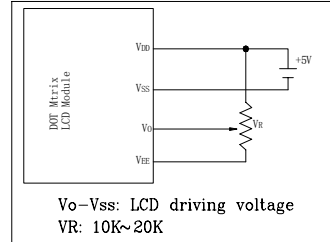

MECHANICAL SPECIFICATIONS

ITEM	SPECIFICATION	UNIT
Module Size (WxHxT)	75X52.7X12[12.5]	mm
Viewing Area (WxH)	60X32.4	mm
Dot Number (WxH)	128x64	dots
Dot Size (WxH)	0.4x0.4	mm
Dot Pitch (WxH)	0.03x0.03	mm
LCD MODE	STN(Y/G,Gray,Blue),FSTN	

PIN ASSIGNMENT

PIN	SYMBOL	FUNCTION
1	VDD	Power Supply (+5V)
2	Vss	Power Supply (0V)
3	Vo	Contrast Adjust
4~11	DB0~DB7	Data bus Line
12	/CS1	Chip select 1
13	/CS2	Chip select 2
14	/RST	Reset Singal
15	RS	Data/Instruction Register Select
16	R/W	Read/Write select
17	E	Enable Signal
18	VEE	Negative Power Out
19,20	A,K	Power Supply

ABSOLUTE MAXIMUM RATINGS

PARAMETER	SYMBOL	MIN.	MAX.	UNIT
Power Supply (logic)	Vdd-Vss	-0.3	7.0	V
Power Supply (LCD)	Vdd-Vo	0.3	15.0	V
Input Voltage	Vi	-0.3	Vdd+0.3	V
Operating Temperature	Topr	0	50	°C
Storage Temperature	Tstg	-20	70	°C

ELECTRICAL CHARACTERISTICS (Ta=25°C)

ITEM	SYMBOL	CONDITION	MIN.	TYP.	MAX.	UNIT
Power Supply (logic)	Vdd	-	4.5	5.0	5.5	V
Supply Current (logic)	Idd	VDD=5.0V	3.0	-	-	mA
Driving Voltage (LCD)	Vdd-Vo		9.0	9.5	10.0	V
Driving Current (LCD)	Ilcd		0	2	-	mA
Input Voltage "H"	Vih		2.2	-	Vdd	V
Input Voltage "L"	Vil	-0.3	-	0.6	V	
Output Voltage "H"	Voh	Ioh=-0.205mA	2.4	-	-	V
Output Voltage "L"	Vol	Iol=1.2mA	-	-	0.4	V

LED BACKLIGHT SPECIFICATIONS(SIZE TYPE)

PARAMETER	TYP.	ITEM	TYP.
Forward Voltage	4.2V	Power Dissipation	1134mW
Forward Current	270mA	Emission Wavelength	nm