

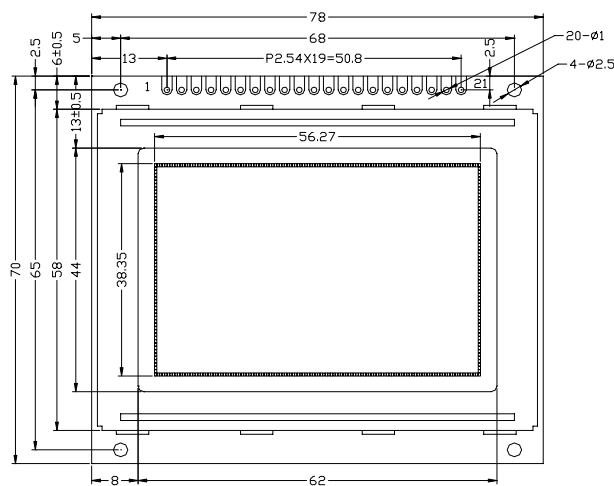

• EXTERNAL DIMENSIONS:

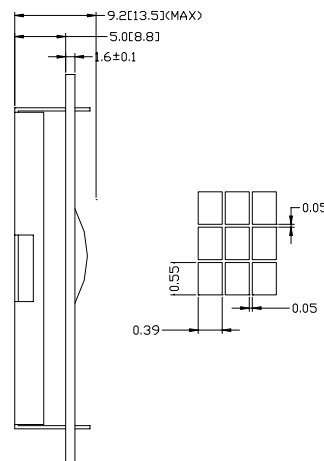

[] For LED Backlight



• BLOCK DIAGRAM:

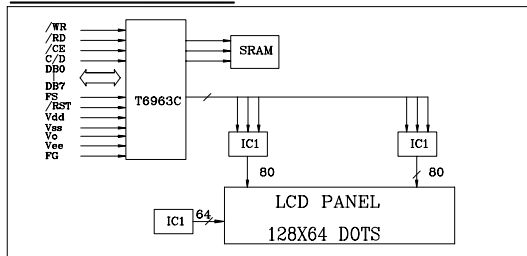

• POWER SUPPLY:

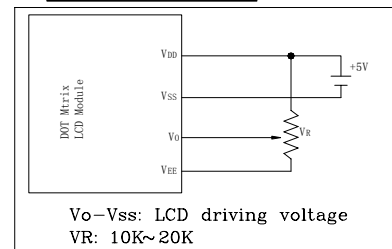

MECHANICAL SPECIFICATIONS

ITEM	SPECIFICATION	UNIT
Module Size (WxHxT)	78.0x70.0x9.2[13.5]	mm
Viewing Area (WxH)	62.0x44.0	mm
Dot Number (WxH)	128x64	dots
Dot Size (WxH)	0.39x0.55	mm
Dot Pitch (WxH)	0.44x0.5	mm
LCD MODE	STN(Y/G,Gray,Blue),FSTN	

PIN ASSIGNMENT

PIN	SYMBOL	FUNCTION
1	FG	Frame Ground
2	Vss	Power Supply (0V)
3	Vdd	Power Supply (+5V)
4	Vo	Contrast Adjust
5	R/W	Read/Write select
6	/RD	Read Signal
7	/CE	Chip Select
8	/CD	Command/Data Select
9	/RST	RESET
10~17	DB0~DB7	Data bus Line
18	FS	Font Select
19	VEE	Negative Power Out
20~21	Backlight	Backlight Power Supply

ABSOLUTE MAXIMUM RATINGS

PARAMETER	SYMBOL	MIN.	MAX.	UNIT
Power Supply (logic)	Vdd-Vss	-0.3	7.0	V
Power Supply (LCD)	Vdd-Vo	0.3	15.0	V
Input Voltage	Vi	-0.3	Vdd+0.3	V
Operating Temperature	Topr	0	50	°C
Storage Temperature	Tstg	-20	70	°C

ELECTRICAL CHARACTERISTICS (Ta=25°C)

ITEM	SYMBOL	CONDITION	MIN.	TYP.	MAX.	UNIT
Power Supply (logic)	Vdd	-	4.5	5.0	5.5	V
Supply Current (logic)	Idd	VDD=5.0V	3.0	-	-	mA
Driving Voltage (LCD)	Vdd-Vo		9.0	9.5	10.0	V
Driving Current (LCD)	Ilcd		0	2	-	mA
Input Voltage "H"	Vih		2.2	-	Vdd	V
Input Voltage "L"	Vil		-0.3	-	0.6	V
Output Voltage "H"	Voh	Ioh=-0.205mA	2.4	-	-	V
Output Voltage "L"	Vol	Iol=1.2mA	-	-	0.4	V

LED BACKLIGHT SPECIFICATIONS(SIZE TYPE)

PARAMETER	TYP.	ITEM	TYP.
Forward Voltage	4.2V	Power Dissipation	1134mW
Forward Current	270mA	Emission Wavelength	nm